



Let MagnumStone<sup>®</sup>  
drive your design.

 **MagnumStone<sup>®</sup>**  
RETAINING WALLS



# Your Gravity Wall just got taller

MagnumStone® Gravity Retaining Wall Extenders replace Geogrid reinforcements by using a tongue-and-groove concrete system to meet or exceed the demands of engineers. This system reduces the massive footprint of traditional cantilevered gravity retaining walls and gives developers and owners greater use of land above the wall.

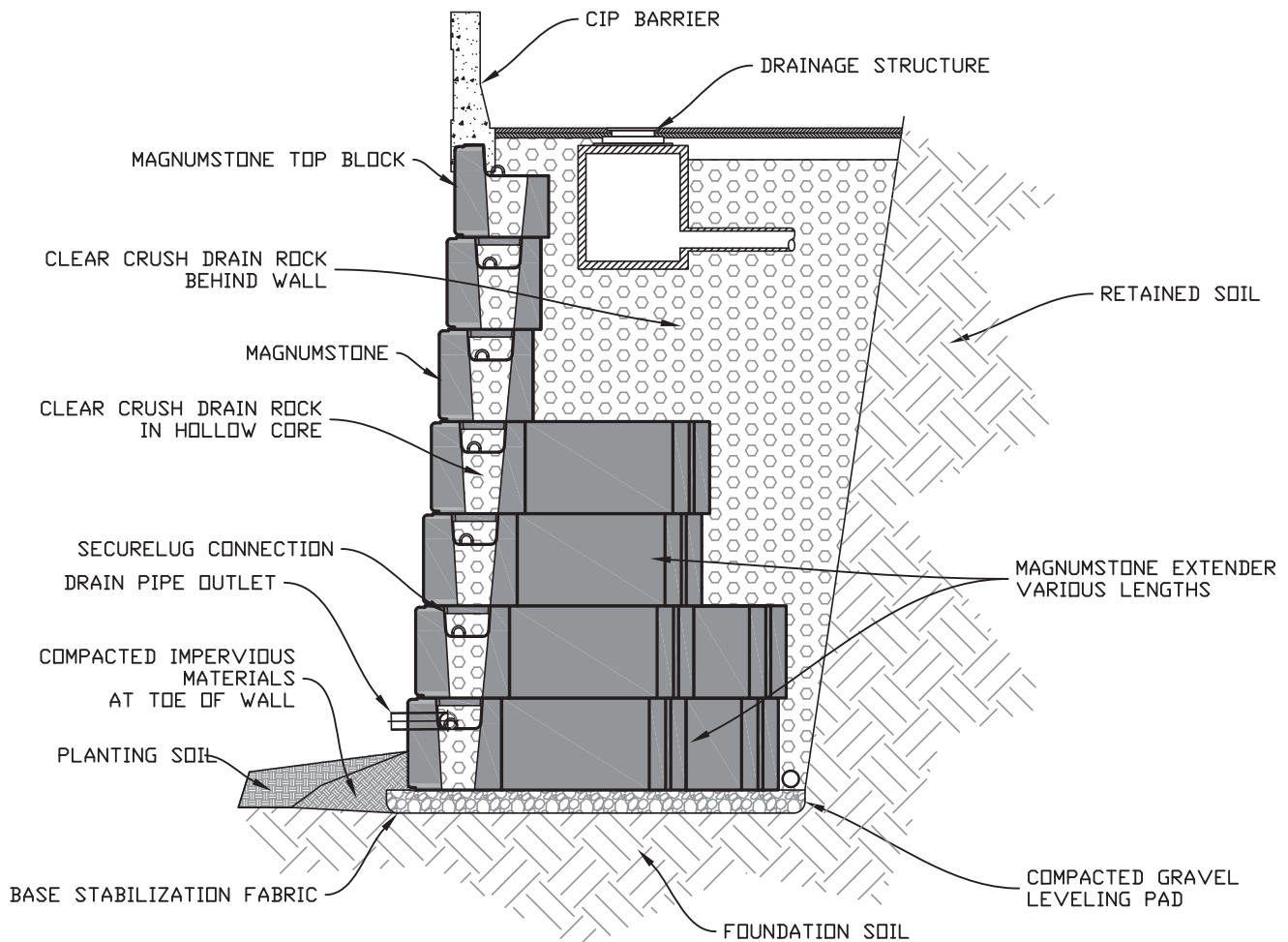



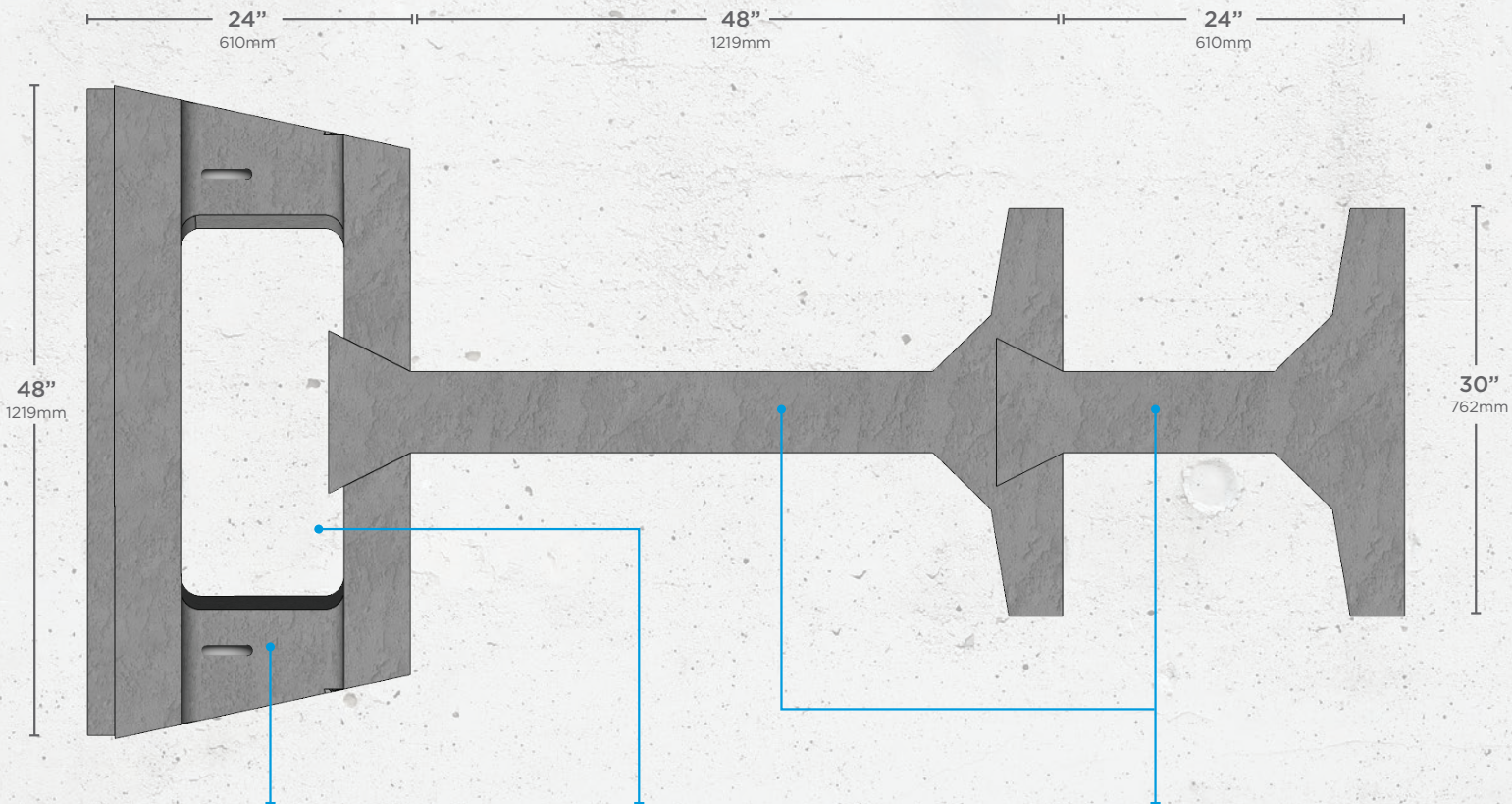

### MagnumStone® Unit

Units are made from high strength, wet cast concrete to provide durability and resistance to weathering.

### Hollow Core

Makes it easy to saw cut, add special lighting, or place fence posts into when adding creative details.

### 4FT & 2FT Extenders

MagnumStone® Extenders can be used in any combination of standard lengths.

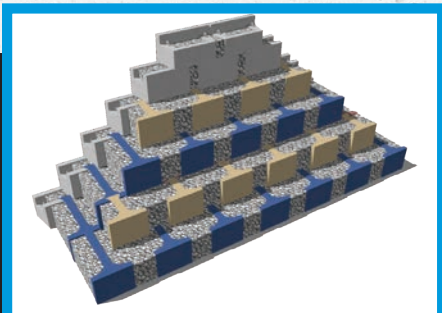

Gravity Wall with Extenders

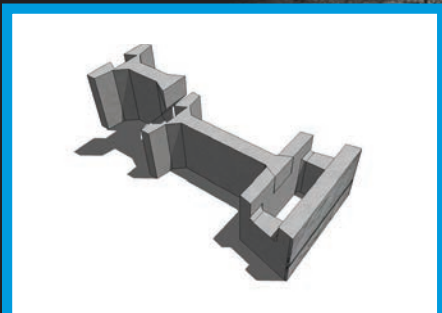

Extender Assembly









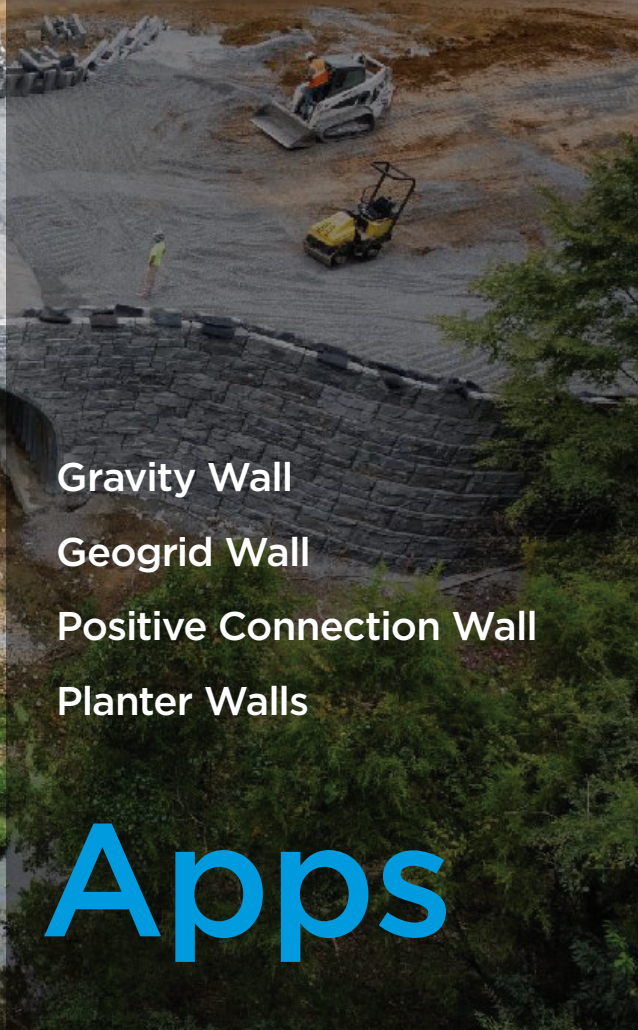

- Gravity Wall
- Geogrid Wall
- Positive Connection Wall
- Planter Walls

# Design Apps



- Soil Nailing Walls
- Cantilever Wall
- Stormwater Management



Fence Posts



# Common Applications



## GRAVITY WALLS

Gravity retaining walls can be built in tight areas with limited excavation space. MagnumStone's gravity retaining wall extenders offer designers the ability to build taller gravity retaining walls by increasing the wall depth in 2 ft. or 4 ft. increments. Gravity extenders deliver impactful performance while further fortifying retaining wall outside corners.



## GEOGRID WALLS

Geogrid retaining wall designs are used to reinforce soil mass and help designers build retaining walls that will resist active forces from above and behind the wall. MagnumStone SecureLug connection offers a superior interlock between the specified grids and the block-to-block connection.

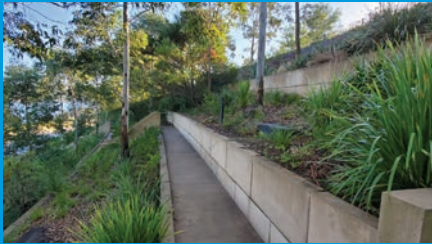

## TERRACES WITH PLANTERS

Terraced planter retaining wall designs work in harmony with MagnumStone's big block retaining wall system. The lightweight, large units allow wall designers the flexible solutions with environmental benefits. The hollow core provides a plantable pocket to increase greenery and reduce the spread of heat island effect, commonly found in concrete surfaces.



## WATER APPLICATIONS

MagnumStone's hollow core offers internal vertical and horizontal drainage design advantages. This minimizes the effects of hydrostatic pressures behind the wall. MagnumStone's wet-cast units provide durable 4,000 psi (27.5 MPa) concrete that's resistant to freeze-thaw cycles and saturated conditions. MagnumStone blocks are optimal for stormwater management solutions including dry ponds, retention ponds and drainage channels.

For more common applications of MagnumStone retaining walls (Steel/Concrete Walls, Soil Nailing, Steel Grid, Free-Standing Walls) visit [magnumstone.com](http://magnumstone.com)

# Design Software

The MagnumStone® Wall Designer program is designed with the Engineer in mind. It includes multiple methodologies, MagnumStone® gravity systems, geogrid friction, and positive reinforcement options for the designer to choose from. Select and edit soil information, input loads and slopes above and below the retaining wall.



# Unit Specifications



## STANDARD

1370 lbs (621 kgs)



## STANDARD BASE

1345 lbs (621 kgs)



## STANDARD TOP

1220 lbs (553 kgs)

Height	24"	610mm
Depth	24"	610mm
Face Width	48"	1219mm
Back Width	39"	991mm
Face Area	8 sq ft	0.745 m2
Setback	4.5° / 2.4° / 0°	



## HALF HIGH

750 lbs (340 kgs)

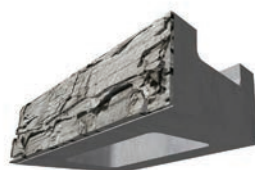

## HALF HIGH BASE

725 lbs (328 kgs)



## HALF HIGH TOP

680 lbs (308 kgs)

Height	12"	305mm
Depth	24"	610mm
Face Width	48"	1219mm
Back Width	39"	991mm
Face Area	4 sq ft	0.37 m2
Setback	4.5° / 2.4° / 0°	



## 2FT EXTENDER

520 lbs (236 kgs)

Height	24"	610mm
Depth	24"	610mm
Back Width	30"	762mm



## 4FT EXTENDER

820 lbs (372 kgs)

Height	24"	610mm
Depth	48"	1219mm
Back Width	30"	762mm

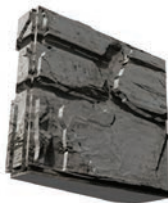

## CORNER/END

340 lbs (154 kgs)



## HALF HIGH CORNER/END

170 lbs (77 kgs)



## STEP/CAP

580 lbs (263 kgs)

Height	24"	610mm
Depth	8"	203mm
Top Width	2"	51mm
Bottom Width	4"	102mm

Height	12"	305mm
Depth	9"	229mm
Top Width	3"	76mm
Bottom Width	4"	102mm

Height	6"	152mm
Depth	24"	609mm
Width	48"	1219mm

## Full Specifications

A full list of specifications can be found on:

[magnumstone.com](http://magnumstone.com)



Dimensions and weights may vary. Please check with local producer.

© Copyright CornerStone® Wall Solutions Inc. All Rights Reserved. | More information can be found at [magnumstone.com](http://magnumstone.com)





**County Materials Corporation**

1203 70th Ave., Roberts WI 54023

Customer Service: 800-242-7733